

## DOT LINE FLOOR

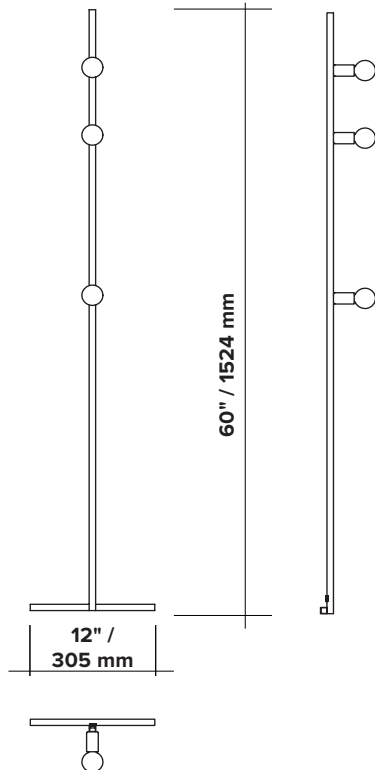

<b>type</b>	floor	
<b>materials</b>	body :	brass (BR) or powder coated aluminium (BL/WH)
	sphere :	milk glass (G50)
	hardware:	brass
	wire :	vinyl
<b>wire length</b>	120" / 3048 mm footswitch positioned at 24" / 610 mm from body	
<b>weight</b>	1.8 lb / 0.8 kg	
<b>sockets</b>	G9	
<b>lightbulb</b>	LED (included), 3x 3,5W	
<b>voltage</b>	120V / 240V	
<b>certifications</b>		
<b>notes</b>	<ul style="list-style-type: none"> <li>- lead time between 8-9 weeks</li> <li>- dimensions are approximate and may vary slightly</li> </ul>	



## ORDER GUIDE: SKU

COLLECTION	MODEL	FINISH
DOT dot	05	BR brass BL black WH white
DOT	05	BR = DOT05BR <i>example</i>

### FINISH



brass



black



white

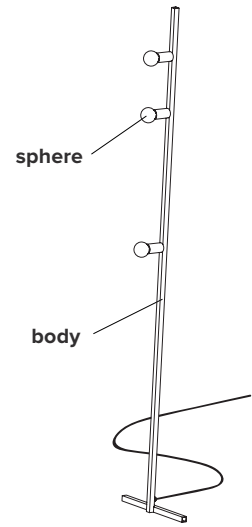

## LIGHT BULB

### G9 SOCKETS

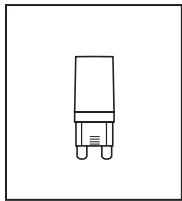

Frosted  
3.5W  
100V-120V / 240V  
350 Lumens  
2700 K  
25 000 H  
CRI ≥80  
2 years warranty



### SPHERES



G100 Ø ±4" / 100 mm



G80 Ø ±3" / 80 mm



G60 Ø ±2" / 60 mm



G50 Ø ±2" / 50 mm



tube Ø 1" / 27 mm  
length ±2" / 60 mm

# DOT LINE FLOOR

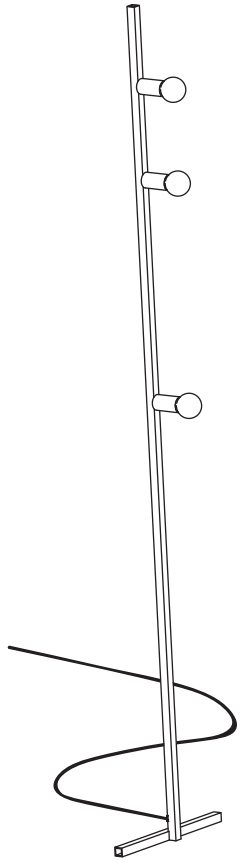

- Wear enclosed gloves when handling lamp
- Handle materials with care. Please consult lamp maintenance sheet on our web site

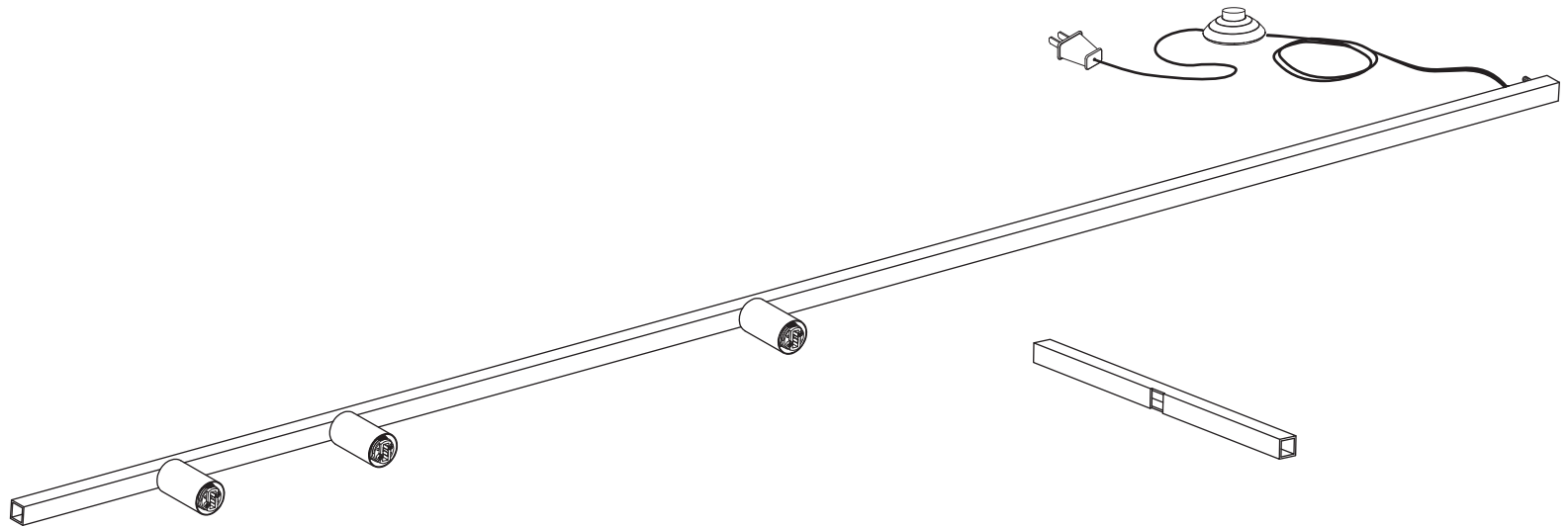
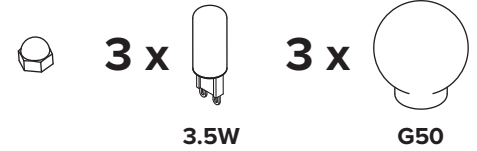

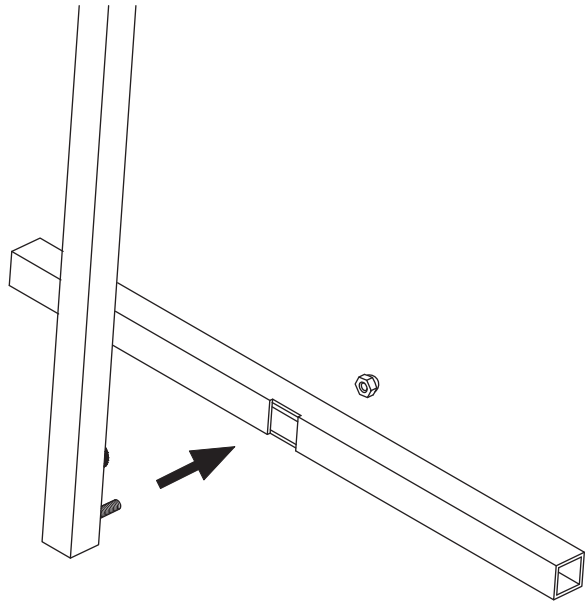

**1**

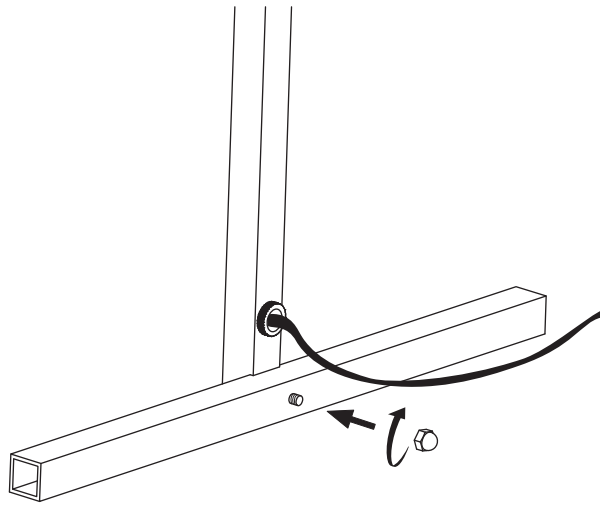

**2**

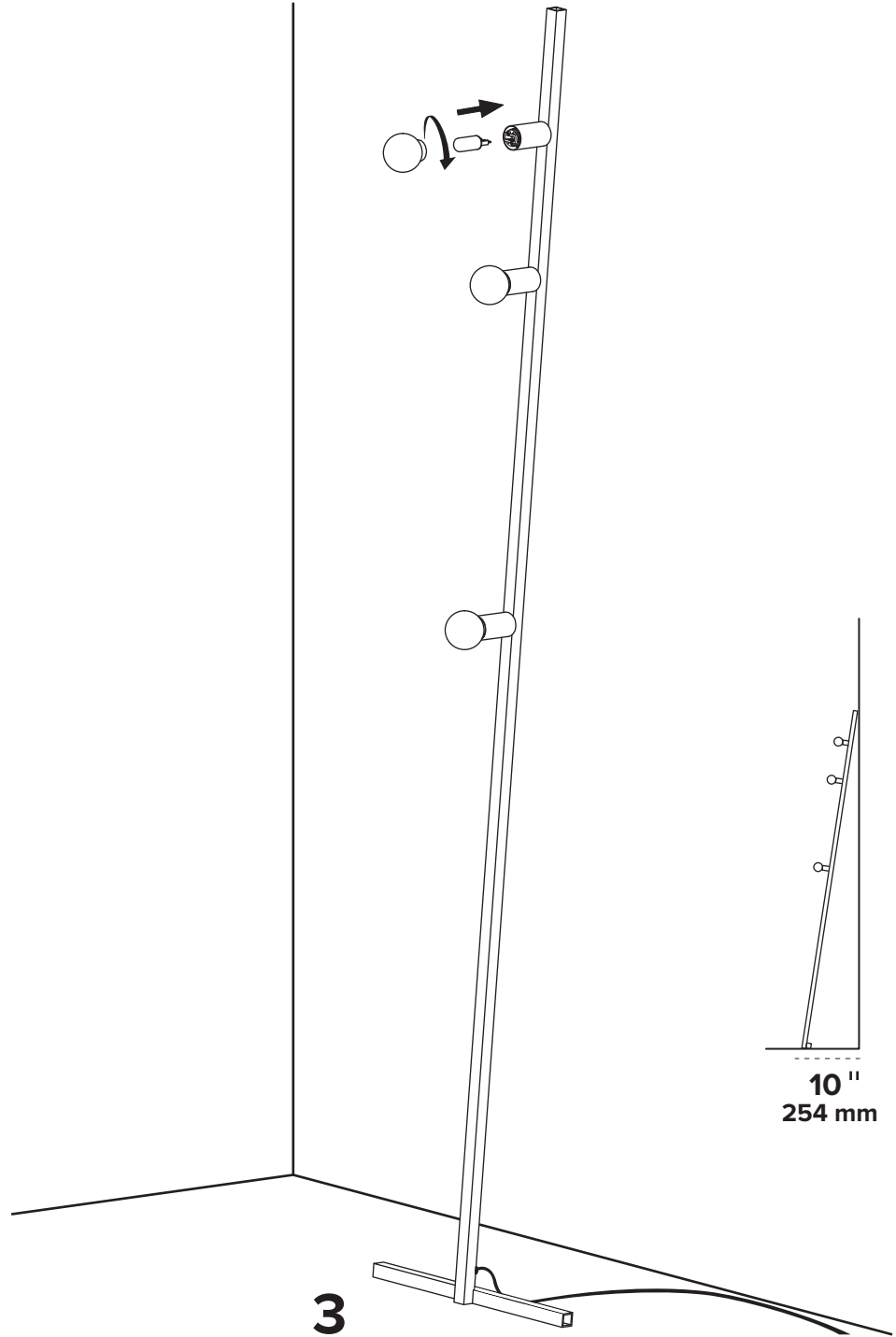

**3**

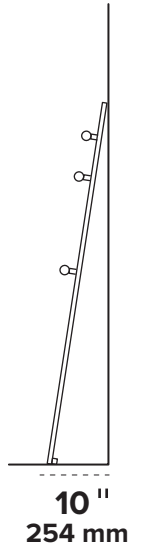

# ENTRETIEN / MAINTENANCE

---

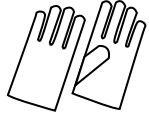

**When handling your light fixture, please use enclosed cotton gloves to avoid blemishes**

## **Unfinished Brass**

If your lamp contains brass components, its look will evolve over time. We work with unfinished brass because we believe brass looks best when it is allowed to build a patina with age.

If you want to restore the lamp's original polished finish, please follow instructions for metal polish.

## **Instructions for use of metal polish (e.g. Collinite No.850 Metal Wax)**

1. Shake product well before application.
2. Using a thin applicator pad, apply a thin amount of metal polish to small sections at a time.
3. Rub well locally to loosen the tarnish.
4. Reapply as necessary until surface is free of contaminants.
5. Before product dries, polish with a dry, clean, and soft microfiber cloth towel.

**WARNING : The above instructions apply to brass components only.**

## **Painted Surface or Graphite Finish**

If your light fixture contains painted surfaces or a graphite finish, it can be cleaned using any all purpose household cleaner. Do not use solvents containing strong chemicals.

**Pour manipuler la lampe, svp utiliser les gants de coton fournis dans la boîte.**

## **Le Laiton brut**

Si votre luminaire comporte des pièces en laiton, sa couleur changera. Ceci n'est pas un défaut de fabrication, mais bien le changement normal de l'apparence du laiton avec le temps. Nous avons choisi comme matière première le laiton brut car nous croyons que le laiton est à son meilleur quand il développe une patine avec l'âge.

Si vous désirez redonner une apparence neuve - polie – à votre luminaire, svp suivre les instructions pour le polissage.

## **Instructions pour l'utilisation de la crème de polissage (ex. Collinite No.850 Metal Wax)**

1. Bien agiter le produit avant l'utilisation.
2. À l'aide d'un chamois ou chiffon doux de coton, verser une fine couche de crème, une section à la fois.
3. Frotter la surface doucement sur les traces foncées du métal terni.
4. Repasser avec la crème de polissage jusqu'à ce qu'il n'y ait plus de traces indésirables.
5. Avant que le produit ne sèche, essuyer la surface avec un chiffon en microfibres sec et propre.

**ATTENTION : Les instructions ci-dessus, ne s'appliquent qu'aux pièces en laiton.**

## **Surfaces Peintes et Fini Graphite**

Si votre luminaire contient des surfaces peintes ou un fini graphite, utiliser n'importe quel produit nettoyant multi-usages standard et un chiffon doux. Éviter tous solvants contenant des produits chimiques forts.