

# CONCORDE

EMMANUEL GALLINA (2009)



## DESCRIPTION

A design able to propose a primary shape, emphasizing the naturalness of the wood for Concorde table by Emmanuel Gallina. Soft shapes interpreted with essential style.

**Poliform**

# CONCORDE

EMMANUEL GALLINA (2009)

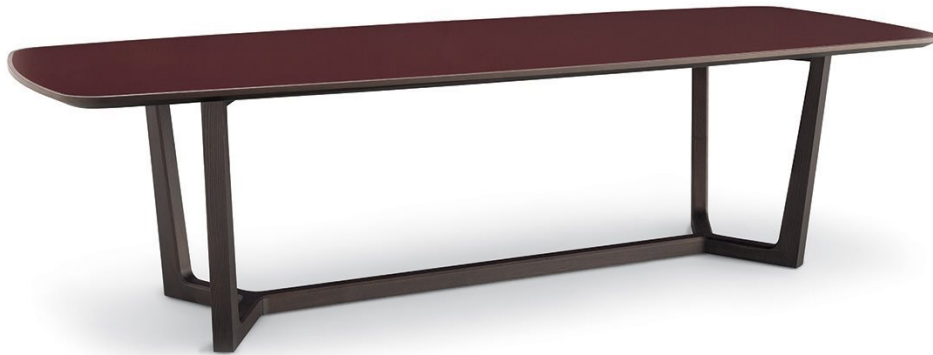

## TECHNICAL DESCRIPTION

### TPOLOGY

fixed table

### LEGS

solid wood

### TOP

available in wood, marble or wood frame with insert in glass. Optional spinning tray only available for round tables

# CONCORDE

EMMANUEL GALLINA (2009)

**TCN218**

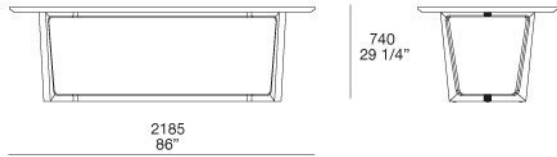

**TCN240**

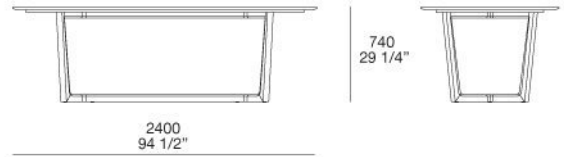

**TCN280**

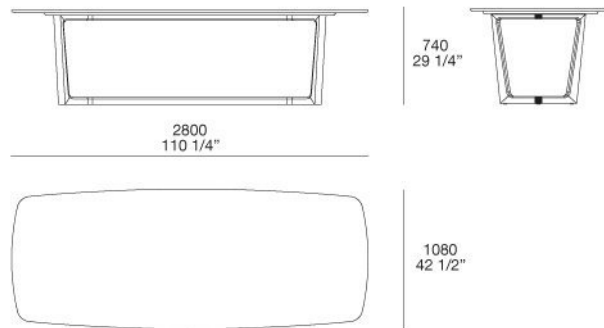

**TCN140R**

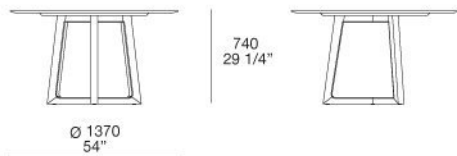

**TCN180R  
PG090**

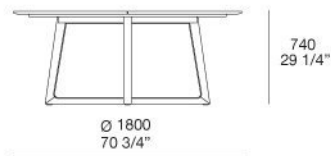

**TCN200R  
PG105**

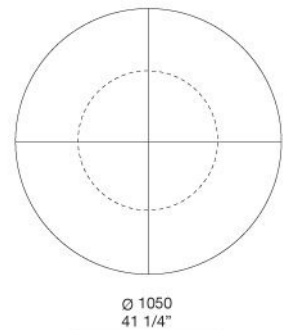
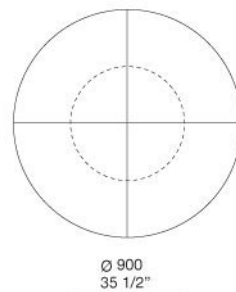
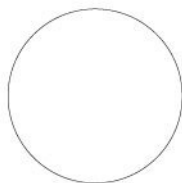
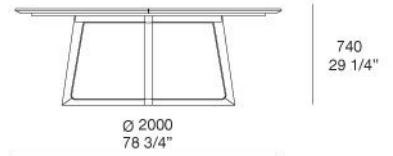

# CONCORDE

FINISHINGS\TOP\MARBLE (10)

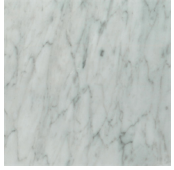

MATT  
BIANCO  
CARRARA

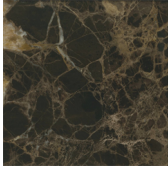

MATT  
EMPERADOR

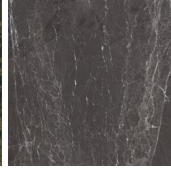

MATT GREY  
STARDUST



MATT  
CALACATTA  
ORO



GLOSSY  
BIANCO  
CARRARA

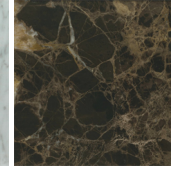

GLOSSY  
EMPERADOR

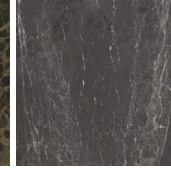

GLOSSY  
GREY  
STARDUST

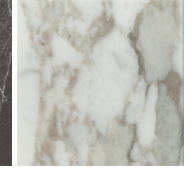

GLOSSY  
CALACATTA  
ORO



GLOSSY  
NOIR SAINT  
LAURENT

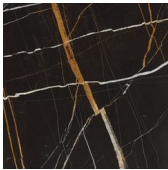

MATT  
SAHARA  
NOIR

# CONCORDE

FINISHINGS\TOP\REFLECTING GLASS (1)



5010 BLUE

# CONCORDE

FINISHINGS\TOP\VETRO CONCORDE (4)



2273  
GHIACCIO  
GLOSSY

1264 ARENA  
GLOSSY

1204  
GRAFITE  
GLOSSY

2259  
BORDEAUX  
GLOSSY

# CONCORDE

FINISHINGS\TOP\WOODS (4)

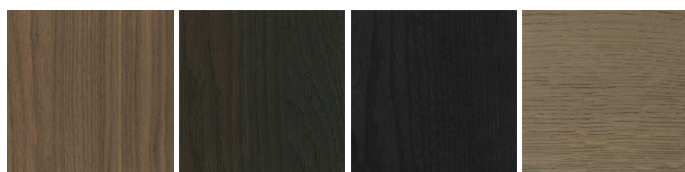

WALNUT C.

SPESSART  
OAK

BLACK ELM

CENERO OAK

# CONCORDE

FINISHINGS\STRUCTURE\WOODS (3)

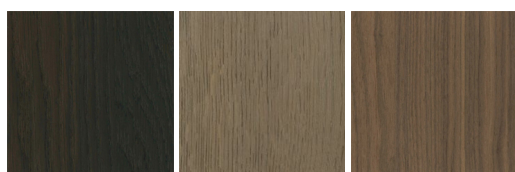

SPESSART  
OAK

CENERO OAK

WALNUT C.

# CONCORDE

FINISHINGS\STRUCTURE\WOODS (1)

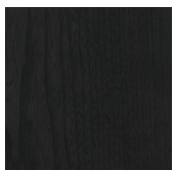

BLACK ELM